

Алматы (7273)495-231
Ангарск (3955)60-70-56
Архангельск (8182)63-90-72
Астрахань (8512)99-46-04
Барнаул (3852)73-04-60
Белгород (4722)40-23-64
Благовещенск (4162)22-76-07
Брянск (4832)59-03-52
Владивосток (423)249-28-31
Владикавказ (8672)28-90-48
Владимир (4922)49-43-18
Волгоград (844)278-03-48
Вологда (8172)26-41-59
Воронеж (473)204-51-73
Екатеринбург (343)384-55-89

Иваново (4932)77-34-06
Ижевск (3412)26-03-58
Иркутск (395)279-98-46
Казань (843)206-01-48
Калининград (4012)72-03-81
Калуга (4842)92-23-67
Кемерово (3842)65-04-62
Киров (8332)68-02-04
Коломна (4966)23-41-49
Кострома (4942)77-07-48
Краснодар (861)203-40-90
Красноярск (391)204-63-61
Курск (4712)77-13-04
Курган (3522)50-90-47
Липецк (4742)52-20-81

Россия +7(495)268-04-70

Магнитогорск (3519)55-03-13
Москва (495)268-04-70
Мурманск (8152)59-64-93
Набережные Челны (8552)20-53-41
Нижний Новгород (831)429-08-12
Новокузнецк (3843)20-46-81
Ноябрьск (3496)41-32-12
Новосибирск (383)227-86-73
Омск (3812)21-46-40
Орел (4862)44-53-42
Оренбург (3532)37-68-04
Пенза (8412)22-31-16
Петрозаводск (8142)55-98-37
Псков (8112)59-10-37

Казахстан +7(7172)727-132

Пермь (342)205-81-47
Ростов-на-Дону (863)308-18-15
Рязань (4912)46-61-64
Самара (846)206-03-16
Саранск (8342)22-96-24
Санкт-Петербург (812)309-46-40
Саратов (845)249-38-78
Севастополь (8692)22-31-93
Симферополь (3652)67-13-56
Смоленск (4812)29-41-54
Сочи (862)225-72-31
Ставрополь (8652)20-65-13
Сургут (3462)77-98-35
Сыктывкар (8212)25-95-17
Тамбов (4752)50-40-97

Киргизия +996(312)96-26-47

Тверь (4822)63-31-35
Тольятти (8482)63-91-07
Томск (3822)98-41-53
Тула (4872)33-79-87
Тюмень (3452)66-21-18
Ульяновск (8422)24-23-59
Улан-Удэ (3012)59-97-51
Уфа (347)229-48-12
Хабаровск (4212)92-98-04
Чебоксары (8352)28-53-07
Челябинск (351)202-03-61
Череповец (8202)49-02-64
Чита (3022)38-34-83
Якутск (4112)23-90-97
Ярославль (4852)69-52-93

www.masterwatt.nt-rt.ru | | mwa@nt-rt.ru

Технические характеристики на стандартные бронированные электронагреватели LOVAR КОМПАНИИ MASTERWATT

FINNED ARMOURED HEATERS

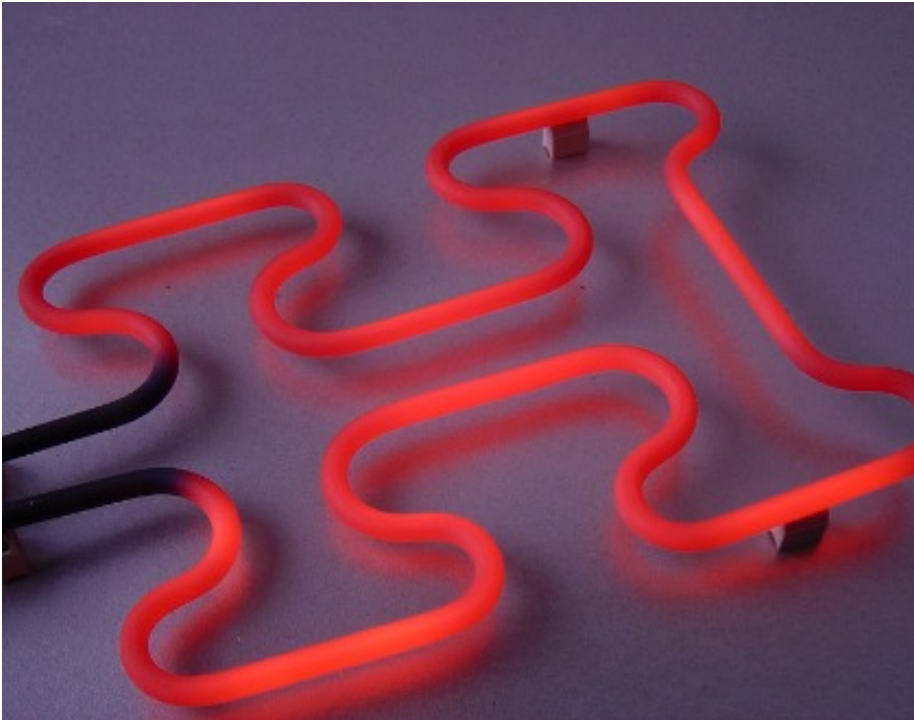

Elementi riscaldanti standard

The finned armoured heaters have been developed to satisfy the need of temperature controlled air or gas flows which is present in several industrial processes. They are also suitable to keep a closed ambient at a specified temperature.

They are designed to be inserted into ventilation ducts or air conditioning plants and are directly flown by the process air or gas. They can also be installed directly inside the ambient to be heated since they are suitable to heat static air or gases.

These heaters are finned to increase the heat exchange. However, if the heated fluid contains particles (which could clog the fins) these heaters cannot be used and smooth armoured heaters shall be used in place.

Figure 1: Typical sketch of a finned armoured heater

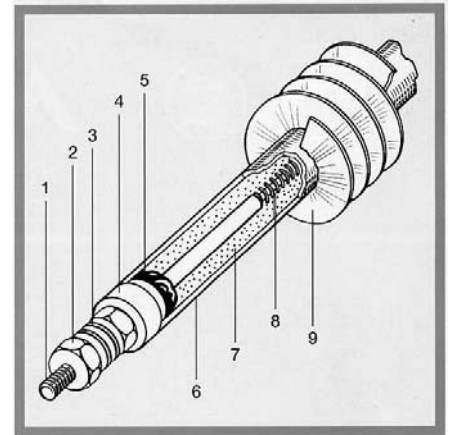
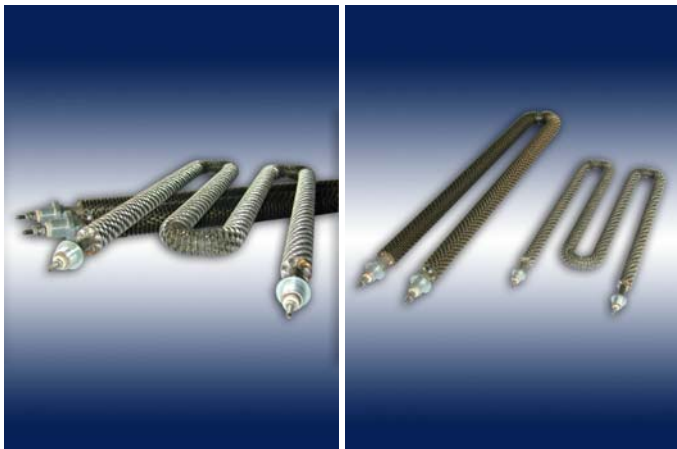

GENERAL CHARACTERISTICS

The finned armoured heaters have been developed to satisfy the need of temperature controlled air or gas flows which is present in several industrial processes. They are also suitable to keep a closed ambient at a specified temperature

They are designed to be inserted into ventilation ducts or air conditioning plants and are directly flown by the process air or gas. They can also be installed directly inside the ambient to be heated since they are suitable to heat static air or gases.

These heaters are finned to increase the heat exchange. However, if the heated fluid contains particles (which could clog the fins) these heaters cannot be used and smooth armoured heaters shall be used in place.

The heaters undergo dimensional and electrical controls all along the production phase, as required by the company Quality Control System (certified in accordance with ISO 9001:2000 Standard). A 100 % electrical acceptance test allows to verify the compliance of each single heater to the requirements specified in the applicable CEI/EN Specification. In particular, the following tests are performed:

- Measurement of the Insulation resistance
- Measurement of the dielectrical rigidity
- Measurement of the dispersion current
- Measurement of the resistance ohmic value

APPLICATIONS

These heaters are used in the heating of closed areas, in air conditioning plants, in the forced ventilation used as part of packaging processes and in drying ovens. A proper choice of the construction materials allows to reach fluid operating temperatures up to 300 ÷ 400 °C.

TECHNICAL DATA (see Figure 1)

1. **TERMINAL STUD** threaded M6 (heaters with 16 mm diameter sheath) or M4 (heaters with 10 mm diameter sheath) made of stainless steel AISI303
2. **NUTS** made of stainless steel AISI304
3. **WASHER** made of stainless steel AISI304
4. **INSULATING BUSH** made of steatite KER221
5. **SILICON SEALING** suitable for high temperatures
6. **SHEATH (or ARMOUR)** made of carbon steel or titanium-alloyed stainless steel AISI316Ti, particularly suitable for high temperatures
7. **ELECTRIC INSULATION** obtained by a high purity MgO powder, suitable for high temperature, with a grains size distribution optimised for this application
8. **RESISTIVE WINDING** spiral made of Nickel/Chrome 80/20 DIN 17470, executed with automatic tools which insure long duration
9. **EXTERNAL FIN** obtained by wounding a 0.5 mm thick ribbon (pitch = 4.5 mm) made of UNI 5866 carbon steel (in case of heaters with carbon steel sheath) or in stainless steel AISI304 (in case of heaters with AISI316Ti sheath).

The manufacturing options are sketched in Figure 2

Figure 2: manufacturing options of finned armoured heaters

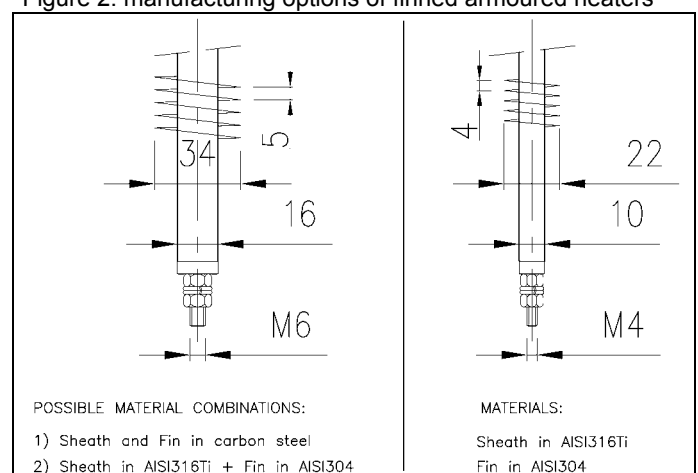

POWER

The finned armoured heaters are normally manufactured with a specific power in the range 2-4 W/cm². If the air or gas flow is sufficiently high, specific power values up to 6-8 W/cm² can be reached

MANUFACTURING ALTERNATIVES

Different manufacturing alternatives exist for this family of heaters. The variables are:

- The sheath diameter (10 or 16 mm)
- The sheath and fin material (sheath and fin made of carbon steel or stainless steel AISI316Ti sheath and AISI304 fin)
- The shape (straight element, "U" or "M" shaped element – see also Figure 3)
- The type of fixation device selected for the heater installation (threaded bush, insulating ceramic bush, positioning washer or fixation plate – see also Figures 4 e 5).

To select, amongst all possible solutions, the one that best suits the application of interest, the customer shall specify at least:

- The fluid to be heated (air or other)
- The type of heating (static or in forced convection) and the temperatures that the fluid shall reach
- The power supply voltage
- The desired mounting solution and the applicable envelope constrains (if any).

Based on this information our specialists will be able to define the best most suitable product and to present an offer.

In all cases the customer can order directly the product of interest specifying the electrical characteristics (power and voltage) and providing a drawing (or even a sketch) of the desired mechanical and dimensional characteristics.

INSTALLATION

These heaters can be fixed onto their supporting structures by means of threaded bushes or mounting plates (only for "U"-shaped elements). For the heaters with a sheath diameter of 16 mm it is possible to use also positioning washers (only for straight elements), and ceramic bushes.

Figure 4 provides dimensional and constructive details of these devices for the heaters with sheath diameter of 16 mm while Figure 5 shows the accessories available for the heaters with sheath diameter of 10 mm.

Figure 3: possible shaped for finned armoured heaters

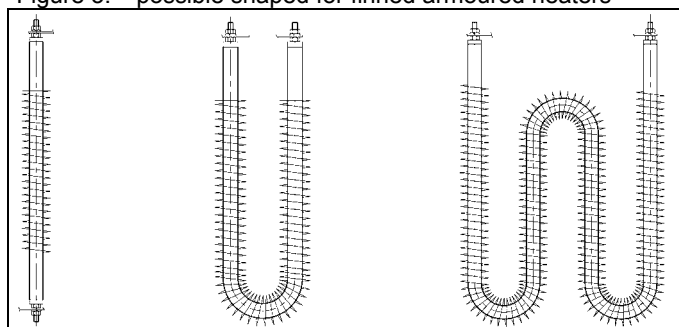

Figure 4: dimensions and constructive characteristics of fixation devices for elements with sheath diameter 16 mm

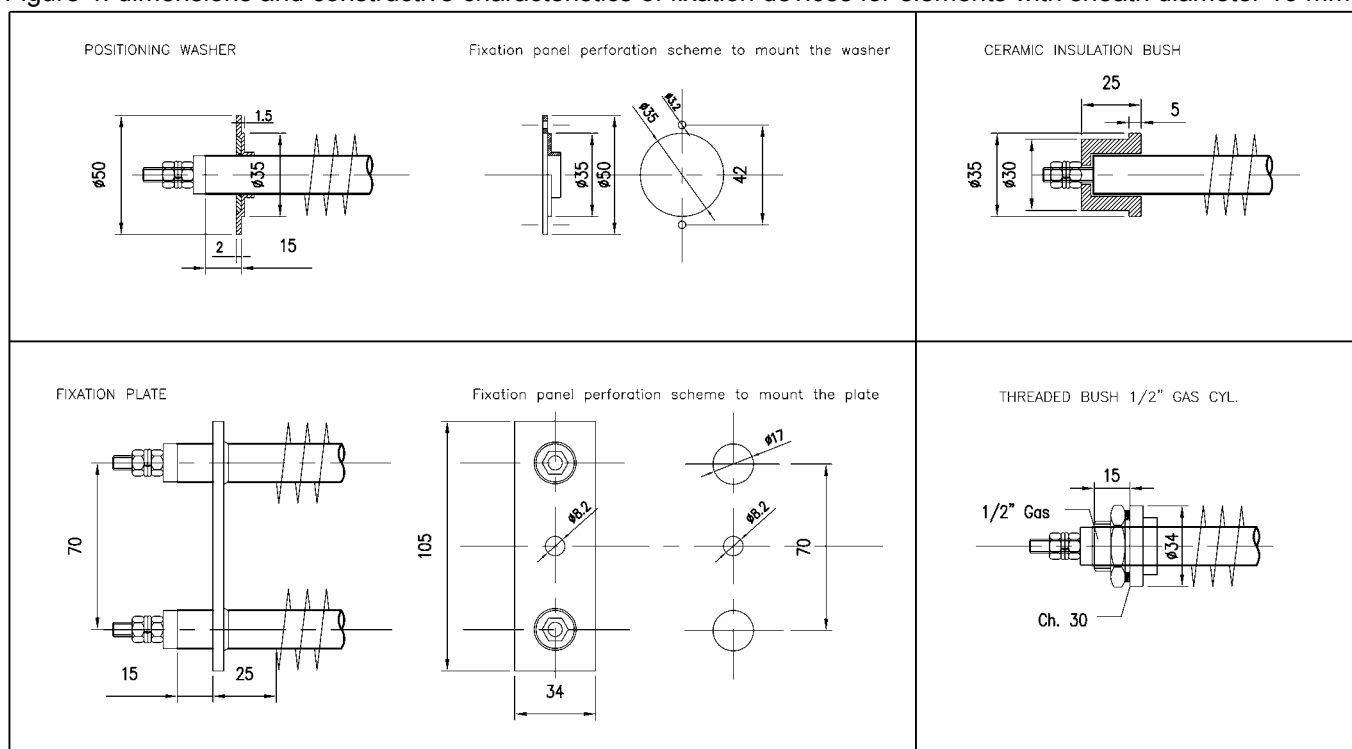
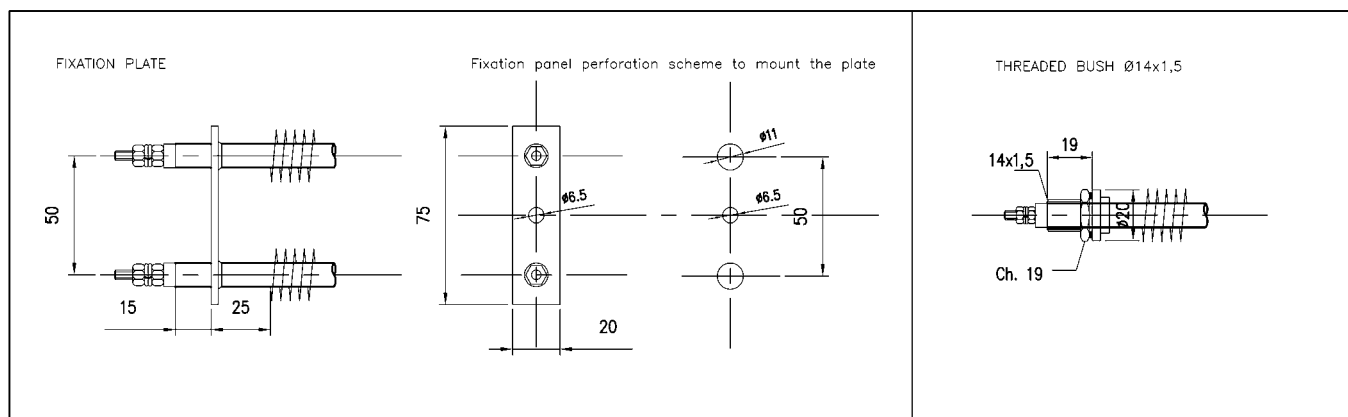

Figure 5: dimensions and constructive characteristics of fixation devices for elements with sheath diameter 10 mm



STANDARD ON STOCK HEATERS

In many cases the heating needs are not very complex but, on the other hand, it is necessary to have the heaters available at a reduced cost and in a limited time.

LOVAR finned heaters have been conceived just to respond to this need: they can heat static air (version with specific power equal to 2 W/cm^2) or air in forced flow (versions with specific power equal to 3 and 4 W/cm^2).

The heating power ranges from a minimum of 300 W up to a maximum of 4 kW. They can operate with air temperatures up to $100 \text{ }^\circ\text{C}$. The power supply voltage is 230V.

These heaters are available in the straight version (family 5516L – see Figure 5) or “U”-bent (family 5516U – see Figure 6).

The install them onto their supporting structures it is possible to order them provided with one of the devices shown in Figure 4.

The complete list of LOVAR heaters available on stock is shown in Table 1.

TECHNICAL DATA

Sheath Material	= carbon steel
Fin Material	= carbon steel
Sheath diameter	= 16 mm
Diameter of the finned part	= 34 mm
Terminal Stud	= threaded M6 x 27 mm
Cold section at each end	= 40 mm
Distance between the studs	= 70 mm (series 5516U)
Power supply voltage	= 230 V
Length	= A (see Table 1)
Power	= P (see Table 1)

Figure 5: manufacturing features of straight LOVAR heaters

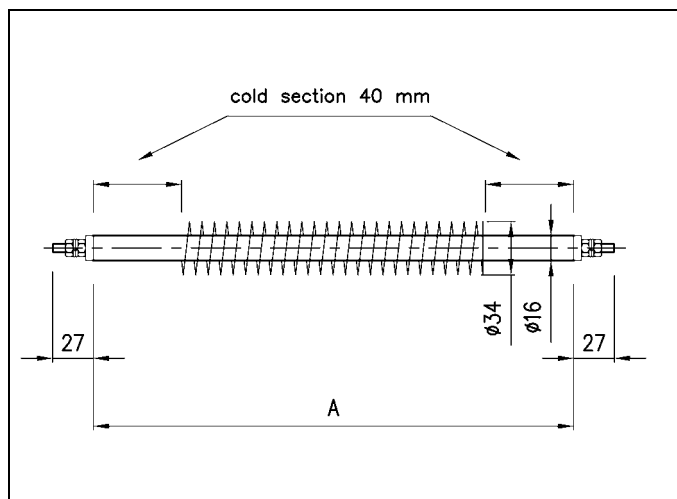

Figure 6: manufacturing features of “U”-shaped LOVAR heaters

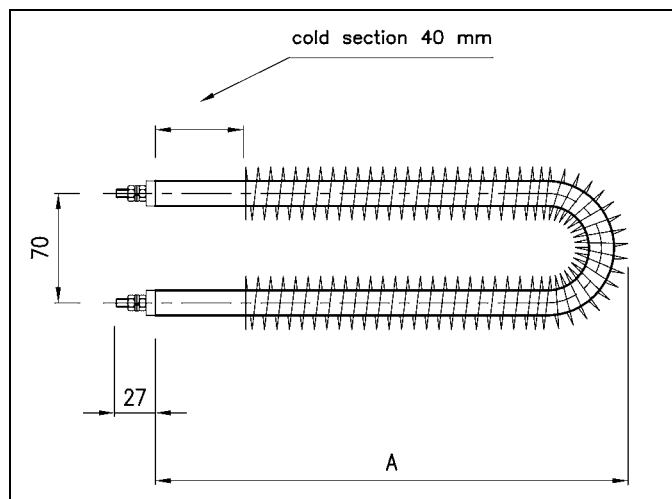

Table 1: Finned LOVAR heaters available on stock

Straight heaters: 2 W/cm ² – 230 V Suitable for static and forced flow air			
Code	A (mm)	Power (W)	Weight (kg)
5516L03500300	350	300	0.570
5516L05500500	550	500	0.900
5516L07500700	750	700	1.230
5516L08500800	850	800	1.300
5516L10501000	1050	1000	1.720
5516L12501200	1250	1200	2.050
5516L13501300	1350	1300	2.210
5516L15501500	1550	1500	2.530
5516L18501800	1850	1800	3.030
5516L20502000	2050	2000	3.350

Straight heaters: 3 W/cm ² – 230 V Suitable for forced airflow: velocity ≥ 3 m/s			
Code	A (mm)	Power (W)	Weight (kg)
5516L04000500	400	500	0.650
5516L05000700	500	700	0.820
5516L06000800	600	800	0.980
5516L07001000	700	1000	1.150
5516L08501200	850	1200	1.400
5516L09001300	900	1300	1.470
5516L10501500	1050	1500	1.720
5516L12501800	1250	1800	2.050
5516L14002000	1400	2000	2.290
5516L17002500	1700	2500	2.780
5516L20503000	2050	3000	3.350
5516L23503500	2350	3500	3.840

Straight heaters: 4 W/cm ² – 230 V suitable for forced airflow: velocity ≥ 4 m/s			
Code	A (mm)	Power (W)	Weight (kg)
5516L04000700	400	700	0.650
5516L04500800	450	800	0.740
5516L05501000	550	1000	0.900
5516L06501200	650	1200	1.060
5516L07001300	700	1300	1.150
5516L08001500	800	1500	1.310
5516L09501800	950	1800	1.550
5516L10502000	1050	2000	1.720
5516L13002500	1300	2500	2.130
5516L15503000	1550	3000	2.530
5516L18003500	1800	3500	2.940
5516L20504000	2050	4000	3.350

"U"-bent heaters: 2 W/cm ² – 230 V Suitable for static and forced flow air			
Code	A (mm)	Power (W)	Weight (kg)
5516U02750500	275	500	0.900
5516U03750700	375	700	1.230
5516U04250800	425	800	1.300
5516U05251000	525	1000	1.720
5516U06251200	625	1200	2.050
5516U06751300	675	1300	2.210
5516U07751500	775	1500	2.530
5516U09251800	925	1800	3.030
5516U10252000	1025	2000	3.350

"U"-bent heaters: 3 W/cm ² – 230 V Suitable for forced airflow: velocity ≥ 3 m/s			
Code	A (mm)	Power (W)	Weight (kg)
5516U02500700	250	700	0.820
5516U03000800	300	800	0.980
5516U03501000	350	1000	1.150
5516U04251200	425	1200	1.400
5516U04501300	450	1300	1.470
5516U05251500	525	1500	1.720
5516U06251800	625	1800	2.050
5516U07002000	700	2000	2.290
5516U08502500	850	2500	2.780
5516U10253000	1025	3000	3.350
5516U11753500	1175	3500	3.840

"U"-bent heaters: 4 W/cm ² – 230 V suitable for forced airflow: velocity ≥ 4 m/s			
Code	A (mm)	Power (W)	Weight (kg)
5516U02250800	225	800	0.740
5516U02751000	275	1000	0.900
5516U03251200	325	1200	1.060
5516U03501300	350	1300	1.150
5516U04001500	400	1500	1.310
5516U04751800	475	1800	1.550
5516U05252000	525	2000	1.720
5516U06502500	650	2500	2.130
5516U07753000	775	3000	2.530
5516U09003500	900	3500	2.940
5516U10254000	1025	4000	3.350

Алматы (7273)495-231
Ангарск (3955)60-70-56
Архангельск (8182)63-90-72
Астрахань (8512)99-46-04
Барнаул (3852)73-04-60
Белгород (4722)40-23-64
Благовещенск (4162)22-76-07
Брянск (4832)59-03-52
Владивосток (423)249-28-31
Владикавказ (8672)28-90-48
Владимир (4922)49-43-18
Волгоград (844)278-03-48
Вологда (8172)26-41-59
Воронеж (473)204-51-73
Екатеринбург (343)384-55-89

Иваново (4932)77-34-06
Ижевск (3412)26-03-58
Иркутск (395)279-98-46
Казань (843)206-01-48
Калининград (4012)72-03-81
Калуга (4842)92-23-67
Кемерово (3842)65-04-62
Киров (8332)68-02-04
Коломна (4966)23-41-49
Кострома (4942)77-07-48
Краснодар (861)203-40-90
Красноярск (391)204-63-61
Курск (4712)77-13-04
Курган (3522)50-90-47
Липецк (4742)52-20-81

Магнитогорск (3519)55-03-13
Москва (495)268-04-70
Мурманск (8152)59-64-93
Набережные Челны (8552)20-53-41
Нижний Новгород (831)429-08-12
Новокузнецк (3843)20-46-81
Ноябрьск (3496)41-32-12
Новосибирск (383)227-86-73
Омск (3812)21-46-40
Орел (4862)44-53-42
Оренбург (3532)37-68-04
Пенза (8412)22-31-16
Петрозаводск (8142)55-98-37
Псков (8112)59-10-37

Пермь (342)205-81-47
Ростов-на-Дону (863)308-18-15
Рязань (4912)46-61-64
Самара (846)206-03-16
Саранск (8342)22-96-24
Санкт-Петербург (812)309-46-40
Саратов (845)249-38-78
Севастополь (8692)22-31-93
Симферополь (3652)67-13-56
Смоленск (4812)29-41-54
Сочи (862)225-72-31
Ставрополь (8652)20-65-13
Сургут (3462)77-98-35
Сыктывкар (8212)25-95-17
Тамбов (4752)50-40-97

Тверь (4822)63-31-35
Тольятти (8482)63-91-07
Томск (3822)98-41-53
Тула (4872)33-79-87
Тюмень (3452)66-21-18
Ульяновск (8422)24-23-59
Улан-Удэ (3012)59-97-51
Уфа (347)229-48-12
Хабаровск (4212)92-98-04
Чебоксары (8352)28-53-07
Челябинск (351)202-03-61
Череповец (8202)49-02-64
Чита (3022)38-34-83
Якутск (4112)23-90-97
Ярославль (4852)69-52-93

Россия +7(495)268-04-70

Казахстан +7(7172)727-132

Киргизия +996(312)96-26-47

www.masterwatt.nt-rt.ru | | mwa@nt-rt.ru