

Алматы (7273)495-231
Ангарск (3955)60-70-56
Архангельск (8182)63-90-72
Астрахань (8512)99-46-04
Барнаул (3852)73-04-60
Белгород (4722)40-23-64
Благовещенск (4162)22-76-07
Брянск (4832)59-03-52
Владивосток (423)249-28-31
Владикавказ (8672)28-90-48
Владимир (4922)49-43-18
Волгоград (844)278-03-48
Вологда (8172)26-41-59
Воронеж (473)204-51-73
Екатеринбург (343)384-55-89

Иваново (4932)77-34-06
Ижевск (3412)26-03-58
Иркутск (395)279-98-46
Казань (843)206-01-48
Калининград (4012)72-03-81
Калуга (4842)92-23-67
Кемерово (3842)65-04-62
Киров (8332)68-02-04
Коломна (4966)23-41-49
Кострома (4942)77-07-48
Краснодар (861)203-40-90
Красноярск (391)204-63-61
Курск (4712)77-13-04
Курган (3522)50-90-47
Липецк (4742)52-20-81

Россия +7(495)268-04-70

Магнитогорск (3519)55-03-13
Москва (495)268-04-70
Мурманск (8152)59-64-93
Набережные Челны (8552)20-53-41
Нижний Новгород (831)429-08-12
Новокузнецк (3843)20-46-81
Ноябрьск (3496)41-32-12
Новосибирск (383)227-86-73
Омск (3812)21-46-40
Орел (4862)44-53-42
Оренбург (3532)37-68-04
Пенза (8412)22-31-16
Петрозаводск (8142)55-98-37
Псков (8112)59-10-37

Казахстан +7(7172)727-132

Пермь (342)205-81-47
Ростов-на-Дону (863)308-18-15
Рязань (4912)46-61-64
Самара (846)206-03-16
Саранск (8342)22-96-24
Санкт-Петербург (812)309-46-40
Саратов (845)249-38-78
Севастополь (8692)22-31-93
Симферополь (3652)67-13-56
Смоленск (4812)29-41-54
Сочи (862)225-72-31
Ставрополь (8652)20-65-13
Сургут (3462)77-98-35
Сыктывкар (8212)25-95-17
Тамбов (4752)50-40-97

Киргизия +996(312)96-26-47

Тверь (4822)63-31-35
Тольятти (8482)63-91-07
Томск (3822)98-41-53
Тула (4872)33-79-87
Тюмень (3452)66-21-18
Ульяновск (8422)24-23-59
Улан-Удэ (3012)59-97-51
Уфа (347)229-48-12
Хабаровск (4212)92-98-04
Чебоксары (8352)28-53-07
Челябинск (351)202-03-61
Череповец (8202)49-02-64
Чита (3022)38-34-83
Якутск (4112)23-90-97
Ярославль (4852)69-52-93

www.masterwatt.nt-rt.ru | | mwa@nt-rt.ru

Технические характеристики на взрывозащищенные каналные обогреватели Ех стандартные каналные обогреватели (воздушно-электрические системы отопления) КОМПАНИИ **MASTERWATT**

AIR DUCT HEATERS

The electric duct are designed to be inserted into ventilation ducts or tubes and are directly flown by the process air or gas.

The heating elements are finned to increase the heat exchange. However, if the heated fluid contains particles which could clog the fins, the duct heater is manufactured using smooth heating elements.

These products are designed taking into account the data already detailed in the section "General Characteristics" and the customer functional requirements.

The iteration between design and analysis leads to define:

1. the elements specific power
2. the resulting pressure drops
3. the maximum sheath temperature, the related safety devices that have to be used and, if the heated gas is potentially explosive, the **temperature class of the heater**
4. the construction materials
5. The heater main dimensions
6. the thermodynamic behaviour of the heater in the foreseen operational conditions

The manufacturing experience built up in several years of operation in the market, coping with the most different applications, enables us to suggest to our customers materials and technical solutions which are best suited to the application of interest.

The results of the preliminary design is provided, in form of a data sheet, already as part of the offer. In particular, the heater temperature class, and the distance (R) of the electrical terminal box, selected to limit the temperatures inside the terminal box itself, are specified

This allows the customer verify the main electric data, the mechanical interfaces to the plant and, above all, **the compatibility between the certification-imposed limitations to the heater use and the plant characteristics.**

Figure 6: Typical sketch of an explosion proof duct heater

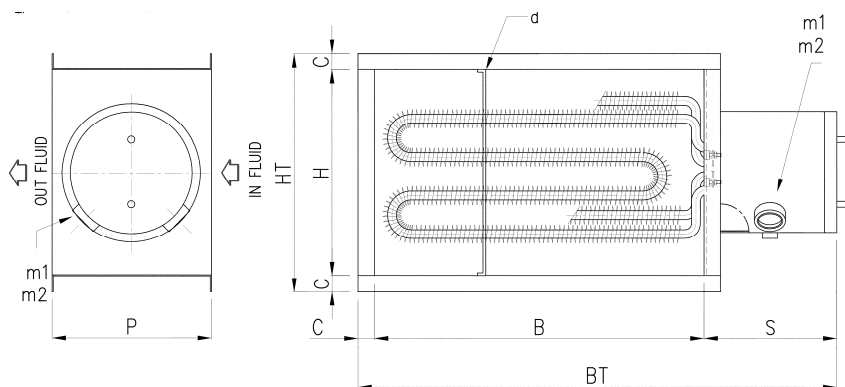

TECHNICAL DATA

(see also Figure 6)

B x H	Air duct section dimensions
BT	Overall width
HT	Overall height
P	Depth
S	Electric terminal box height
C	Frame height
M1	Female sleeve for power cable glands
M2	Female sleeves for signal cable glands

Some examples of explosion proof air duct heaters are shown in the pictures below.



Explosion proof duct heaters

Ex



Explosion proof duct heaters Ex

The electric duct HEATERS are designed to be inserted into ventilation ducts or tubes and are directly flown by the process air or gas.

The heating elements are finned to increase the heat exchange. However, if the heated fluid contains particles which could clog the fins, the duct heater is manufactured using smooth heating elements.

Masterwatt has acquired very high capability to install up to 1 MW in duct heater system, according to the process data of customers. Construction could be tailor made with Carbon steel material and Stainless steel according to special rules and requirements (NACE).

FEATURES:

EXPLOSION PROOF DUCT HEATER certified to: ATEX , IECex, CSA, INMETRO, ATEX, EAC TR-CU standards.

Certified under EN 60079-0, EN 60079-1, EN 60079-7, EN 60079-31 Execution IIB-IIC / Zone 1-2/ Ex-d/Ex-e

Алматы (7273)495-231
Ангарск (3955)60-70-56
Архангельск (8182)63-90-72
Астрахань (8512)99-46-04
Барнаул (3852)73-04-60
Белгород (4722)40-23-64
Благовещенск (4162)22-76-07
Брянск (4832)59-03-52
Владивосток (423)249-28-31
Владикавказ (8672)28-90-48
Владимир (4922)49-43-18
Волгоград (844)278-03-48
Вологда (8172)26-41-59
Воронеж (473)204-51-73
Екатеринбург (343)384-55-89

Иваново (4932)77-34-06
Ижевск (3412)26-03-58
Иркутск (395)279-98-46
Казань (843)206-01-48
Калининград (4012)72-03-81
Калуга (4842)92-23-67
Кемерово (3842)65-04-62
Киров (8332)68-02-04
Коломна (4966)23-41-49
Кострома (4942)77-07-48
Краснодар (861)203-40-90
Красноярск (391)204-63-61
Курск (4712)77-13-04
Курган (3522)50-90-47
Липецк (4742)52-20-81

Магнитогорск (3519)55-03-13
Москва (495)268-04-70
Мурманск (8152)59-64-93
Набережные Челны (8552)20-53-41
Нижний Новгород (831)429-08-12
Новокузнецк (3843)20-46-81
Ноябрьск (3496)41-32-12
Новосибирск (383)227-86-73
Омск (3812)21-46-40
Орел (4862)44-53-42
Оренбург (3532)37-68-04
Пенза (8412)22-31-16
Петрозаводск (8142)55-98-37
Псков (8112)59-10-37

Пермь (342)205-81-47
Ростов-на-Дону (863)308-18-15
Рязань (4912)46-61-64
Самара (846)206-03-16
Саранск (8342)22-96-24
Санкт-Петербург (812)309-46-40
Саратов (845)249-38-78
Сеvastополь (8692)22-31-93
Симферополь (3652)67-13-56
Смоленск (4812)29-41-54
Сочи (862)225-72-31
Ставрополь (8652)20-65-13
Сургут (3462)77-98-35
Сыктывкар (8212)25-95-17
Тамбов (4752)50-40-97

Тверь (4822)63-31-35
Тольятти (8482)63-91-07
Томск (3822)98-41-53
Тула (4872)33-79-87
Тюмень (3452)66-21-18
Ульяновск (8422)24-23-59
Улан-Удэ (3012)59-97-51
Уфа (347)229-48-12
Хабаровск (4212)92-98-04
Чебоксары (8352)28-53-07
Челябинск (351)202-03-61
Череповец (8202)49-02-64
Чита (3022)38-34-83
Якутск (4112)23-90-97
Ярославль (4852)69-52-93

Россия +7(495)268-04-70

Казахстан +7(7172)727-132

Киргизия +996(312)96-26-47

www.masterwatt.nt-rt.ru | | mwa@nt-rt.ru