

Алматы (7273)495-231
Ангарск (3955)60-70-56
Архангельск (8182)63-90-72
Астрахань (8512)99-46-04
Барнаул (3852)73-04-60
Белгород (4722)40-23-64
Благовещенск (4162)22-76-07
Брянск (4832)59-03-52
Владивосток (423)249-28-31
Владикавказ (8672)28-90-48
Владимир (4922)49-43-18
Волгоград (844)278-03-48
Вологда (8172)26-41-59
Воронеж (473)204-51-73
Екатеринбург (343)384-55-89

Иваново (4932)77-34-06
Ижевск (3412)26-03-58
Иркутск (395)279-98-46
Казань (843)206-01-48
Калининград (4012)72-03-81
Калуга (4842)92-23-67
Кемерово (3842)65-04-62
Киров (8332)68-02-04
Коломна (4966)23-41-49
Кострома (4942)77-07-48
Краснодар (861)203-40-90
Красноярск (391)204-63-61
Курск (4712)77-13-04
Курган (3522)50-90-47
Липецк (4742)52-20-81

Россия +7(495)268-04-70

Магнитогорск (3519)55-03-13
Москва (495)268-04-70
Мурманск (8152)59-64-93
Набережные Челны (8552)20-53-41
Нижний Новгород (831)429-08-12
Новокузнецк (3843)20-46-81
Ноябрьск (3496)41-32-12
Новосибирск (383)227-86-73
Омск (3812)21-46-40
Орел (4862)44-53-42
Оренбург (3532)37-68-04
Пенза (8412)22-31-16
Петрозаводск (8142)55-98-37
Псков (8112)59-10-37

Казахстан +7(7172)727-132

Пермь (342)205-81-47
Ростов-на-Дону (863)308-18-15
Рязань (4912)46-61-64
Самара (846)206-03-16
Саранск (8342)22-96-24
Санкт-Петербург (812)309-46-40
Саратов (845)249-38-78
Севастополь (8692)22-31-93
Симферополь (3652)67-13-56
Смоленск (4812)29-41-54
Сочи (862)225-72-31
Ставрополь (8652)20-65-13
Сургут (3462)77-98-35
Сыктывкар (8212)25-95-17
Тамбов (4752)50-40-97

Киргизия +996(312)96-26-47

Тверь (4822)63-31-35
Тольятти (8482)63-91-07
Томск (3822)98-41-53
Тула (4872)33-79-87
Тюмень (3452)66-21-18
Ульяновск (8422)24-23-59
Улан-Удэ (3012)59-97-51
Уфа (347)229-48-12
Хабаровск (4212)92-98-04
Чебоксары (8352)28-53-07
Челябинск (351)202-03-61
Череповец (8202)49-02-64
Чита (3022)38-34-83
Якутск (4112)23-90-97
Ярославль (4852)69-52-93

www.masterwatt.nt-rt.ru | | mwa@nt-rt.ru

Технические характеристики на радиаторные обогреватели инфракрасные INFRARED КОМПАНИИ MASTERWATT

INFRARED HEATERS



INFRARED heaters

INFRARED radiators are the best solution to set up radiation heating systems based on the use of infrared rays. Their emission factor is 0.96, i.e. very close to the maximum theoretical value of 1, and their manufacturing standard allows to insure:

- Long operational life
- Fast heat transmission
- Constant emission along the operational life
- Perfect heating uniformity
- Easy installation

Heating systems using INFRARED radiators heat easily and quickly moving objects. The dimensional and manufacturing characteristics of the heat radiators allow the construction of “open” ovens, normally installed around mobile surfaces (e.g. conveyor belts) inside which it is possible to reach in a short time the desired temperatures without presenting significant heat losses throughout the oven inlet and outlet sections. In addition, if the operational temperature is adequately selected, high specific power densities (higher than those typical of conduction or convection heating), can be obtained.

INFRARED

- Infrared Heaters with Ceramic Insulation -



GENERAL CHARACTERISTICS

INFRARED radiators are the best solution to set up radiation heating systems based on the use of infrared rays. Their emission factor is 0.96, i.e. very close to the maximum theoretical value of 1, and their manufacturing standard allows to insure:

- Long operational life
- Fast heat transmission
- Constant emission along the operational life
- Perfect heating uniformity
- Easy installation

TECHNICAL DATA (see Figure 1)

1. **RESISTIVE WINDING** spiral made of Nickel/Chrome 80/20 DIN 17470, material n° 2.4869
2. **INSULATION** made of high purity ceramic which presents a high resistance to thermal shocks and a high dielectrical rigidity
3. **SURFACE FINISH** particular treatment that protects the insulating body from oxidation, corrosion and water sprays.
4. **FIXATION BASE** standard for a 15x41 mm slot
5. **POWER SUPPLY CABLES** made of Nickel, insulated using ceramic bushes resistant to high temperatures
6. **THERMOCOUPLE** type K (Nickel/Chrome-Nickel - optional)

HEATING BY RADIATION

The rapid growth of the technology in the field of plastic materials processing has requested the development a large variety of electric heaters, capable to transfer efficiently the heat in the most different operational conditions. The most common applications adopt the heat transfer by direct contact or by convection. There are cases, however, in which peculiar process characteristics (rapid working cycle, necessity to heat moving objects, impossibility to seal the heating process inside a volume that is closed to the external environment) do not allow to use effectively the heating by conduction or convection. In these case the most appropriate solution is to adopt a heat transfer by radiation.

The heating by radiation allows to heat easily and quickly moving objects. The dimensional and manufacturing characteristics of the heat radiators allow the construction of "open" ovens, normally installed around mobile surfaces (e.g. conveyor belts) inside which it is possible to reach in a short

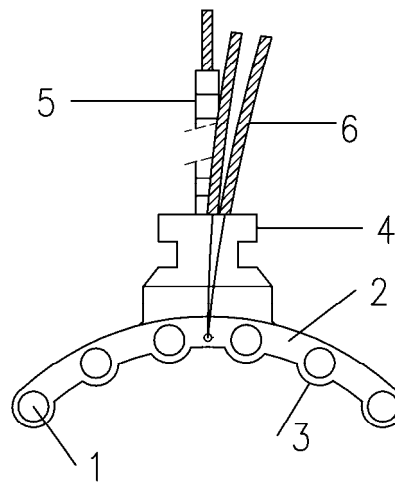
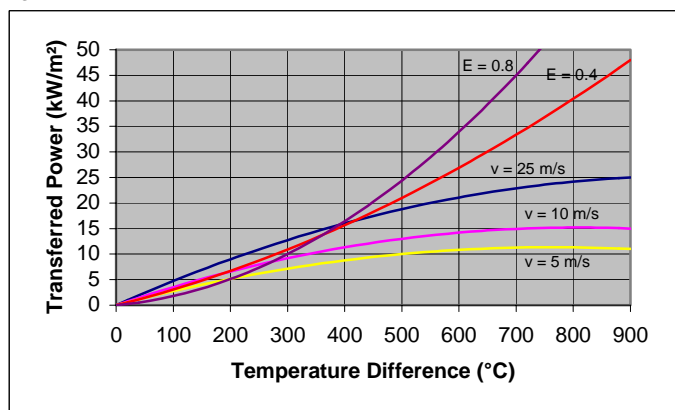

Figure 1

time the desired temperatures without presenting significant heat losses throughout the oven inlet and outlet sections. In addition, if the operational temperature is adequately selected, high specific power densities (higher than those typical of conduction or convection heating), can be obtained.

Figure 2:



This last consideration is clearly shown in the graph of Figure 2 where the specific power transferred by forced convection (3 different air velocity values are considered) and the one obtained by heat radiation (2 different values of the emission factor are analysed) are compared.

The selection of the heat radiators operating temperature shall be performed taking into account different and conflicting needs: on one hand the specific radiated power increases at higher radiators operational temperatures and reaches its peak for wavelength values around 2 μm (see graph in Figure 3), on the other hand, the heat absorption by the radiated bodies is higher when the radiators temperature is low (see Figure 4), which correspond to wavelength values in the range 4 \div 5 μm . Since a radiation heating system based on 300 \div 400 $^{\circ}\text{C}$ operating temperatures would imply a too long heating time, typically the operating temperature is set to 600 \div 800 $^{\circ}\text{C}$ which corresponds to a peak emission wavelength of about 3 μm (see Figure 5).

Figure 3: radiated power as a function of the operating temperature and of the wavelength

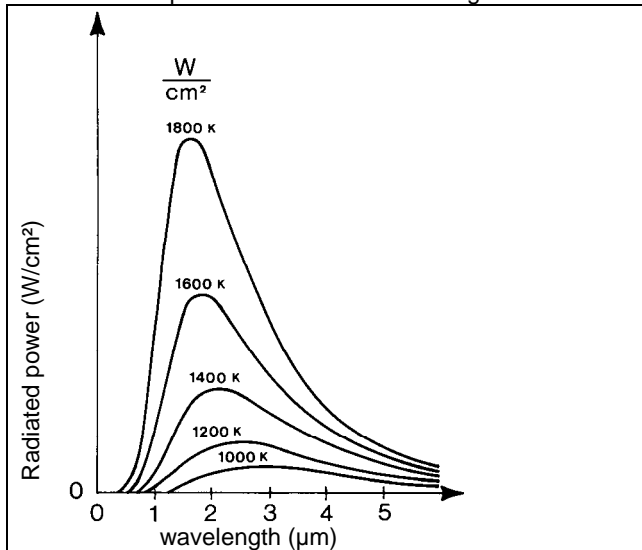

Figure 4: percentage absorbance of radiated energy for different materials

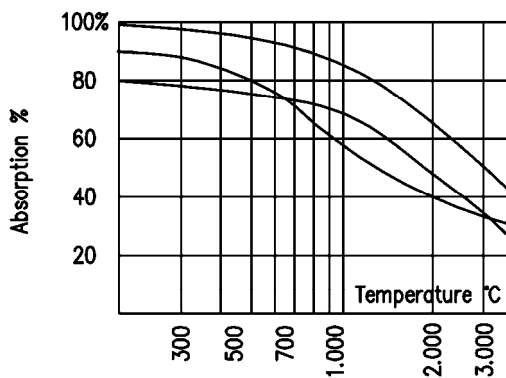
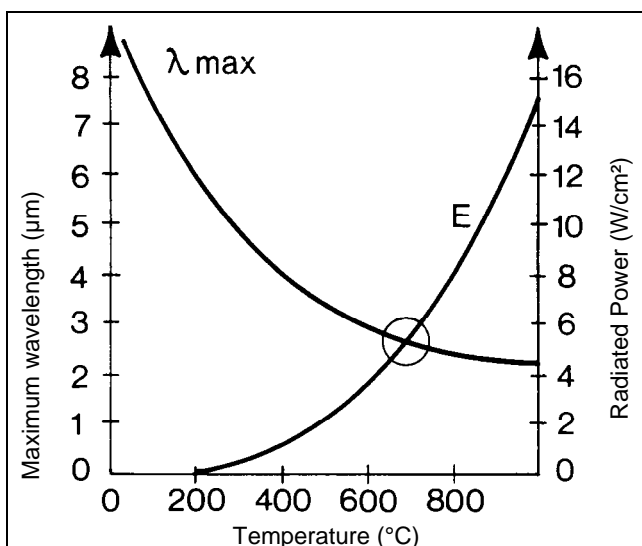

Figure 5 choice of radiators operating temperature

APPLICATIONS

INFRARED radiators are suitable for all applications in which infrared radiation heating is requested. In particular, they are best suited in thermoforming, in the heating of moulds as well as in the drying and thermal fixation processes.

The individual radiators power size is also a function of the application. In fact, depending on the application, radiators with different heating powers are recommended (see Table 1 for the selection criteria).

Table 1: radiators heating power selection criteria

APPLICATION	250 W	400 W	650 W	1000 W
Water Evaporation			⊙	⊙
Drying of plastic or latex coatings		⊙		
Fast drying of glued surfaces		⊙		
Thermoforming, skin-pack		⊙		
Drying of adhesives onto glued parts		⊙		
Heating and drying in shoes fabrication			⊙	⊙
Drying of leather and skins after dyeing	⊙			
Drying of painted metallic parts		⊙	⊙	
Drying of dyes on tissues			⊙	⊙
Thermal fixation, Nylon, Perlon, Tergal	⊙	⊙		
Baking of paints on metal sheets	⊙	⊙		
Heating and drying of food products	⊙			
Thermography			⊙	⊙
Heating of moulds in industrial applications		⊙	⊙	

To correctly define the individual radiators heating power size it is also necessary to correlate the specific power of each radiator to the chemical and physical characteristics of material to be heated. In addition, the desired operational temperature and the duration of the heating process shall also be taken into account to make the correct choice. The graph in Figure 6 shows, for different radiator heating power sizes, the radiated specific power as a function of the distance of the material to be heated.

Figure 6: radiators specific power for different radiator sizes

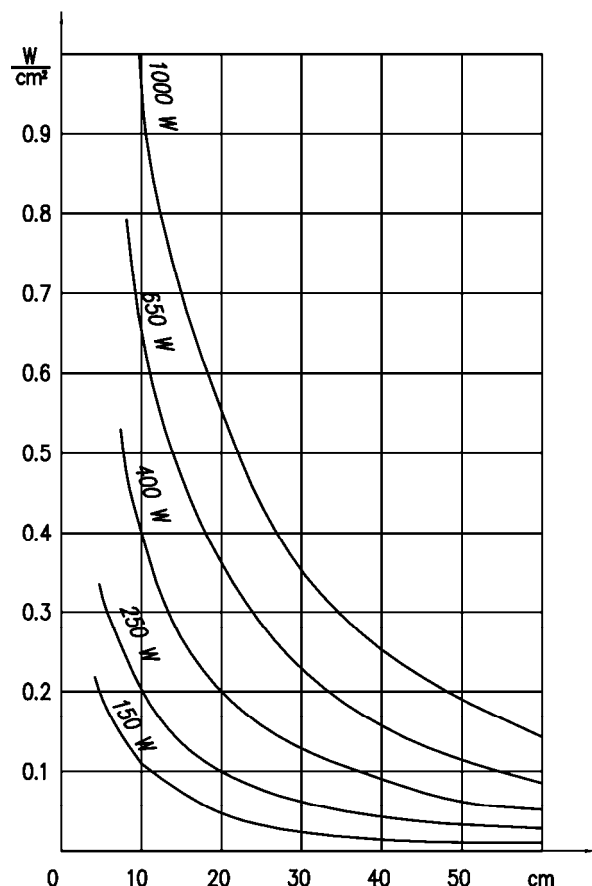

The distribution of the radiated thermal energy is not constant in the volume around the radiator. It is maximum in the direction perpendicular to the radiator axis and decreases when the distance from this direction increases. Also this aspect shall be taken into account in the choice of the radiators and in the definition of their position within the heating system.

In particular, if the product to be heated has a flat shape and it can be positioned parallel to the radiators assembly, it is more convenient to use flat radiators, placed as much as possible close to the product. In this way the reduction of the radiated power, due to a non perfectly orthogonal position of the product with respect to the radiators, is minimised. In addition, thanks to the reduced distance, the heat transfer is very effective (see also graph in Figure 6) and the plant overall dimensions are limited.

If, on the other hand, the product to be heated has an uneven surface, the only way to obtain a uniform heating is to employ curved radiators placed at a certain distance from the product (in order to reduce the heating non uniformity) and installed in a way that allows to keep the product surfaces, which are nearer to the radiators, as much as possible, far from the radiators perpendiculars (see also Figure 8).

La Figure 7 shows, using a polar diagram representation, the radiated energy percentage reduction, which characterises a curved radiator type IC, as a function of the angle between any given direction and the radiator perpendicular axis. With the help of this graph it is possible to define the radiators layout within the heated volume that best suits the characteristics of the product to be heated

Figure 7: polar diagram of the radiated energy distribution

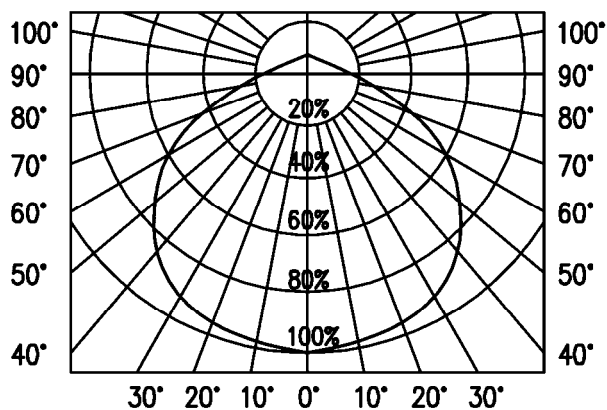

INSTALLATION

The radiators shall be mounted onto a reflecting surface. To obtain a good temperature uniformity on the material ($\pm 1\%$) it is necessary to distribute them as shown in Figure 8.

To fix the radiator to the reflecting surface, each radiator is provided with 2 fixation springs to be used as shown in Figure 9.

Figure 8: correct radiators layout

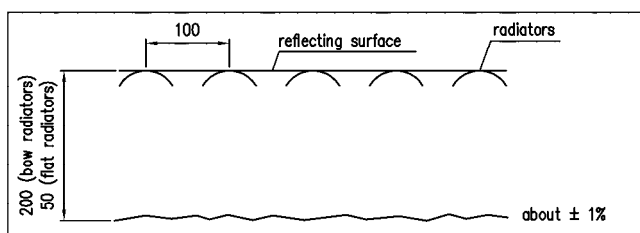
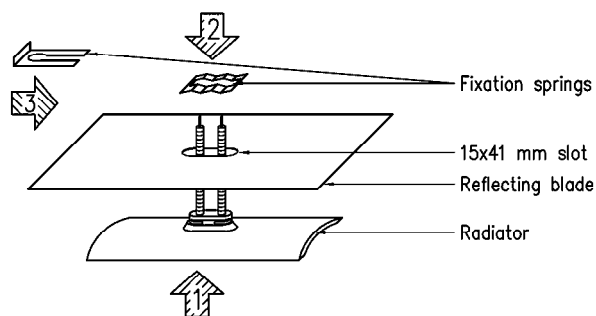

Figure 9: mounting scheme of an INFRARED radiator



STANDARD DIMENSIONS

INFRARED radiators are available on stock. Two typologies can be provided:

- Curved radiators TYPE IC – produced in dimensions 123 x 60 mm and 245 x 60 mm
- Flat radiators TYPE IP – produced in dimensions 123 x 123 mm

To install them, three different mounting panel typologies have been developed. They are available in lengths ranging from 250 mm to 1500 mm:

- RAD TYPE IC for curved INFRARED
- RAD TYPE IP/123 for flat square INFRARED

The electrical and dimensional characteristics of these products are shown in the following pages.

SPECIAL CONSTRUCTIONS

Upon request, INFRARED radiators with supply voltage and heating power different from the standard can be produced.

In addition, it is possible to request mounting panels of the type RAD IC and RAD IP/123 with dimensions different from the standard

Finally, INFRARED radiators with embedded thermocouple type K Nickel-Chrome/Nickel (see next paragraph), can also be provided on request.

INFRARED WITH EMBEDDED THERMOCOUPLE

These radiators shall be used when it is necessary to control the overall performances of the heating system. At changing radiator temperatures, in fact, the radiated power, and, consequently, the temperature reached by the product to be heated, changes. This last parameter, therefore, can be set controlling adequately the radiators temperature.

For an effective temperature control, the number of radiators with embedded thermocouple shall be reasonably proportional to the dimensions of the radiating system.

As an example, if the system is wide, it is recommended to control separately the radiators placed at the borders of the hot area and those placed at the centre. This allows, in fact, to compensate the higher heat leaks of the border areas.

Attention! The control system shall be set taking into account that the temperature measured by the thermocouple is about 10 % lower than the radiator surface temperature. The thermocouple electrical connection shall be performed using compensated cable type KX-CHROME-ALUMEL (see thermocouples catalogue).

INFRARED RADIATORS

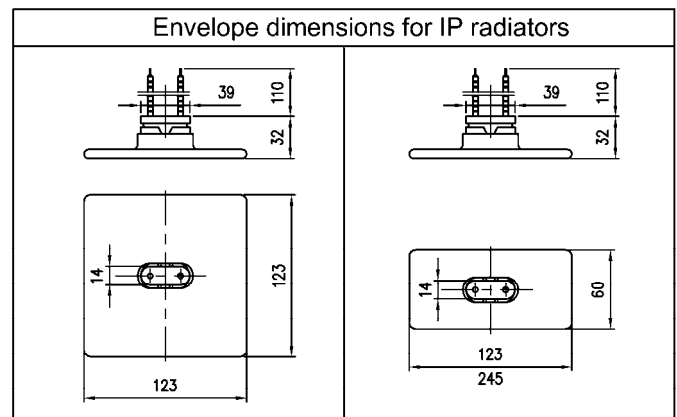
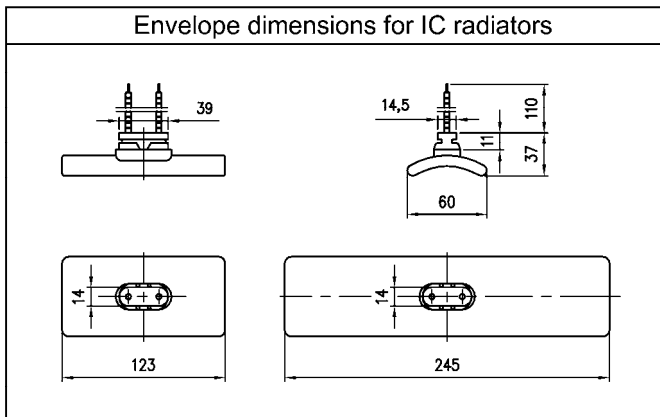

RADIATORS TYPE IC and TYPE IP which are available on stock are listed in the following tables.

CURVED RADIATORS mm 123 x 60							
TYPE IC	Code without thermocouple	Code with thermocouple type K (NiCr/Ni)	Power at 230 V (W)	Average Surface Temperature (°C)	Main Wavelength (µm)	Heating rate from 0 to 90 °C (°C/min)	Cooling time down to 100 °C (min)
	26IC0601230125	27IC0601230125	125	415	4.5	73	7.5
	26IC0601230200	27IC0601230200	200	500	3.9	108	9
	26IC0601230325	27IC0601230325	325	620	3.2	170	9.8
	26IC0601230500	27IC0601230500	500	730	2.8	240	10.2
	CURVED RADIATORS mm 245 x 60						
26IC0602450150	27IC0602450150	150	315	5.3	40	5.4	
26IC0602450250	27IC0602450250	250	415	4.5	73	7.5	
26IC0602450400	27IC0602450400	400	500	3.9	108	9	
26IC0602450650	27IC0602450650	650	620	3.2	170	9.8	
26IC0602451000	27IC0602451000	1000	730	2.8	240	10.2	

FLAT RADIATORS mm 123 x 123							
TYPE IP	Code without thermocouple	Code with thermocouple type K (NiCr/Ni)	Power at 230 V (W)	Average Surface Temperature (°C)	Main Wavelength (µm)	Heating rate from 0 to 90 °C (°C/min)	Cooling time down to 100 °C (min)
	26IP1231230150	27IP1231230150	150	305	5.3	52	4.8
	26IP1231230250	27IP1231230250	250	415	4.5	88	6.5
	26IP1231230400	27IP1231230400	400	505	3.9	130	7.9
	26IP1231230650	27IP1231230650	650	600	3.2	200	8.9

MOUNTING PANELS RAD TYPE IC



RAD IC panels are designed to allow the installation of the **curved radiators TYPE IC 123 x 60 and 245 x 60**.

They consist of a reflecting bow made of stainless steel and by a U-shaped structural support made of aluminised steel. If requested, a protection box, to enclose all the electrical contacts, can be provided (see solutions OPEN PANEL and CLOSED PANEL in Figure 11) The U-shaped support is perforated to make the routing of the cables possible and to allow the fixation of the electrical terminals. The reflecting bow, the U-shaped support and, if foreseen, the protection box are assembled together by means of screws and spacers as shown in Figure 10 aside.

The U-shaped support is produced in two separate versions which are relevant to two different mounting systems.

In the first version, the length of the U-shaped support that is 80 mm longer than the one of the reflecting bow. Two lateral slots are also provided, which allow the fixation of the panel to the main system structure without interfering with the panel internal mounting systems ("External Fixation" concept).

In the second version, the length of the U-shaped support is identical to the one of the reflecting bow. In this case, the screws employed for the lateral closure of the panel are also used to fix the assembled panel to the main system structure ("Internal Fixation" concept).

In conclusion, for each reflecting box length, three mounting solutions are possible:

- OPEN PANEL with External or Internal Fixation
- CLOSED PANEL with External Fixation

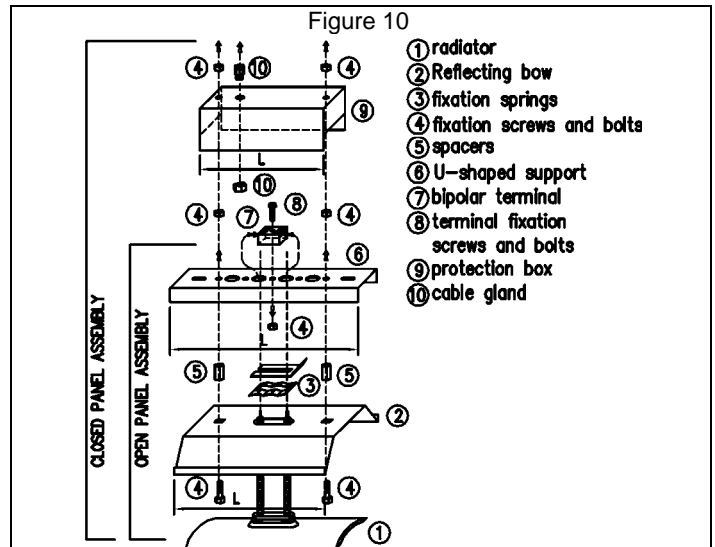
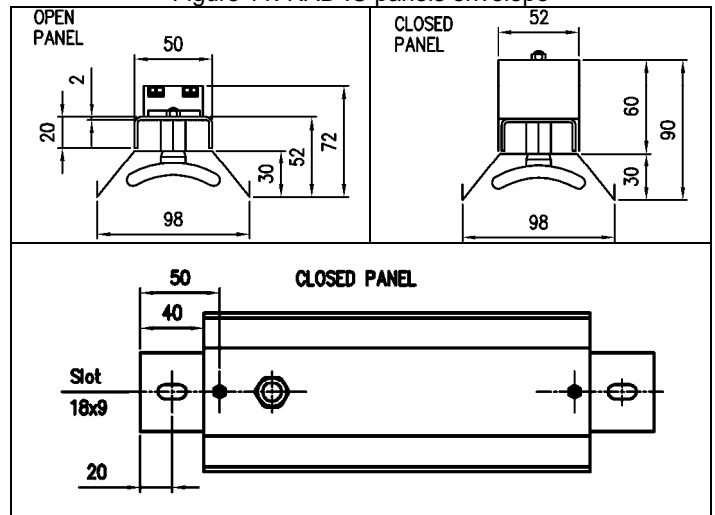

Figure 11: RAD IC panels envelope



REFLECTING BOW FOR IC 123 x 60	REFLECTING BOW FOR IC 245 x 60	U-SHAPED SUPPORT with Internal Fixation	U-SHAPED SUPPORT with External Fixation	PROTECTION BOX	OPEN PANEL with Internal Fixation	OPEN PANEL with External Fixation	CLOSED PANEL	INFRARED TYPE IC QUANTITY	
								IC 123 x 60	IC 245 x 60
L mm	L mm	L mm	L mm	L mm	L mm	L mm	L mm		
250	250	250	330	250	250	250	250	2	1
Code 756208943	Code 756208901	Code 756208923	Code 756208915	Code 756208908					
500	500	500	580	500	500	500	500	4	2
Code 756208944	Code 756208902	Code 756208924	Code 756208916	Code 756208909					
750	750	750	830	750	750	750	750	6	3
Code 756208945	Code 756208903	Code 756208925	Code 756208917	Code 756208910					
1000	1000	1000	1080	1000	1000	1000	1000	8	4
Code 756208946	Code 756208904	Code 756208926	Code 756208918	Code 756208911					
1250	1250	1250	1330	1250	1250	1250	1250	10	5
Code 756208947	Code 756208905	Code 756208927	Code 756208919	Code 756208912					
1500	1500	1500	1580	1500	1500	1500	1500	12	6
Code 756208948	Code 756208906	Code 756208928	Code 756208920	Code 756208913					

7
8
 BIPOLAR TERMINAL WITH SCREWS AND BOLTS (1 Terminal per radiator) CODE: M538ST021108B
4
5
 INSTALLATION KIT COMPOSED BY SPACERS, SCREWS AND BOLTS (1 Kit per reflecting bow) CODE : 4229TP01

MOUNTING PANELS RAD TYPE IP/123

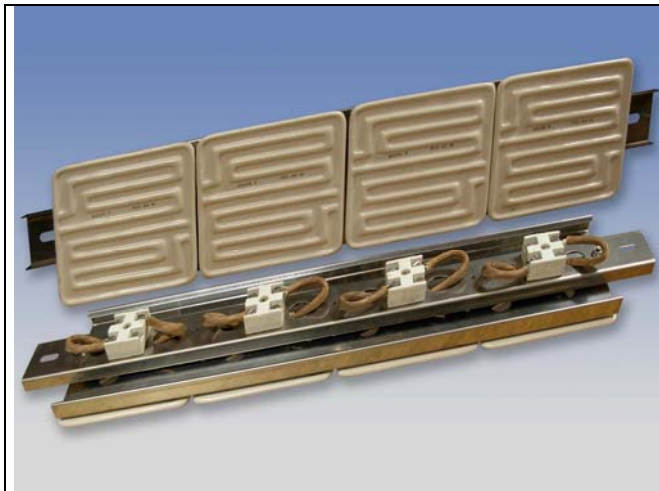

RAD IP/123 panels are designed to allow the installation of the flat radiators TYPE IP 123 x 123.

They are manufactured using a flat reflecting sheet made of stainless steel and by a U-shaped structural support made of aluminised steel. Available lengths and mounting systems are the same as those presented for the RAD IC panels.

Figure 12

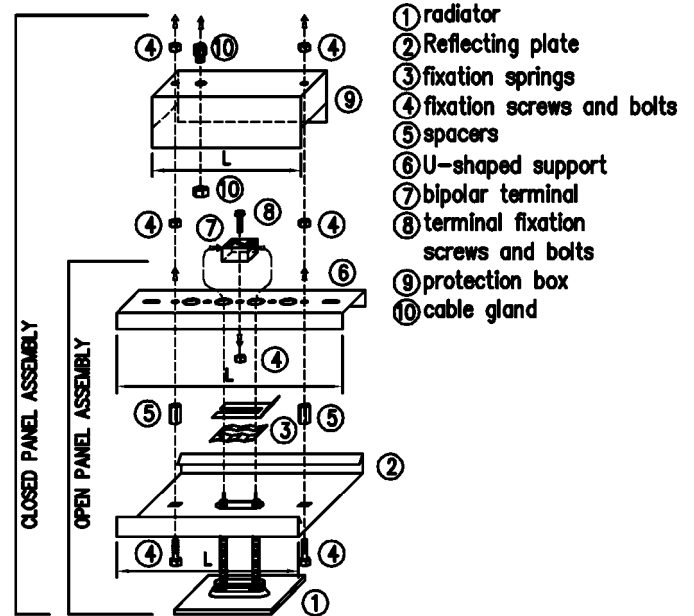
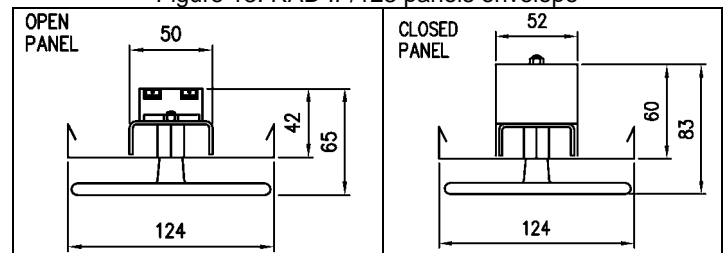

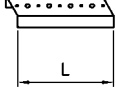
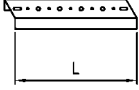

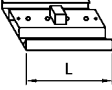
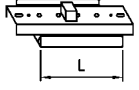
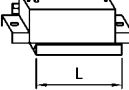

Figure 13: RAD IP/123 panels envelope



REFLECTING SHEET	U-SHAPED SUPPORT with INTERNAL FIXATION	U-SHAPED SUPPORT with EXTERNAL FIXATION	PROTECTION BOX	OPEN PANEL with INTERNAL FIXATION	OPEN PANEL with EXTERNAL FIXATION	CLOSED PANEL	INFRARED QUANTITY
 L mm	 L mm	 L mm	 L mm	 L mm	 L mm	 L mm	IP 123 x 123
250 Code 756208937	250 Code 756208923	330 Code 756208915	250 Code 756208908	250	250	250	2
500 Code 756208938	500 Code 756208924	580 Code 756208916	500 Code 756208909	500	500	500	4
750 Code 756208939	750 Code 756208925	830 Code 756208917	750 Code 756208910	750	750	750	6
1000 Code 756208940	1000 Code 756208926	1080 Code 756208918	1000 Code 756208911	1000	1000	1000	8
1250 Code 756208941	1250 Code 756208927	1330 Code 756208919	1250 Code 756208912	1250	1250	1250	10
1500 Code 756208942	1500 Code 756208928	1580 Code 756208920	1500 Code 756208913	1500	1500	1500	12
(7) (8) BIPOLAR TERMINAL WITH SCREWS AND BOLTS (1 Terminal per radiator) CODE: M538ST021108B							
(4) (5) INSTALLATION KIT COMPOSED BY SPACERS, SCREWS AND BOLTS (1 Kit per reflecting bow) CODE : 4229TP01							

QUARTZRED

- Infrared Heaters with Tubular Quartz Insulation -

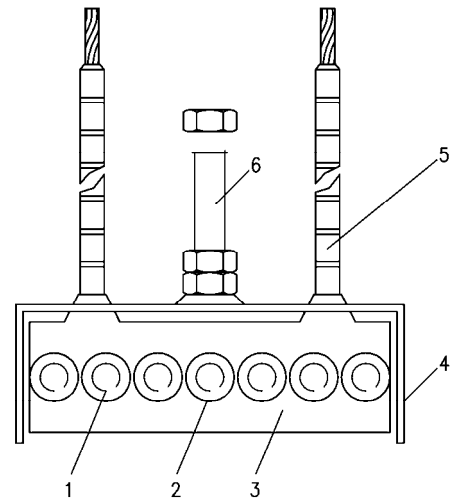
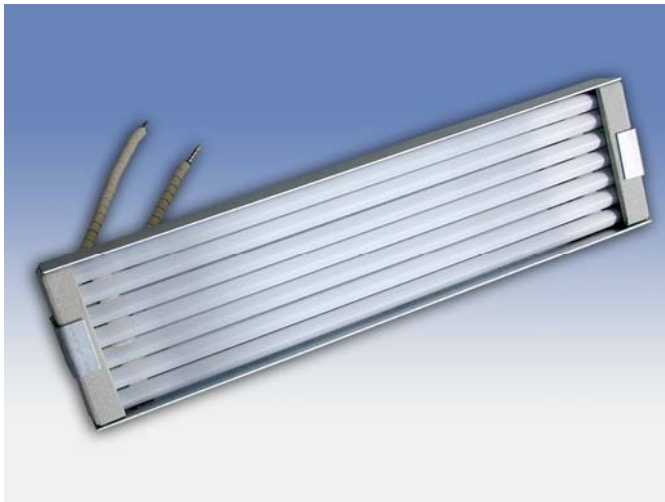

Figure 15

GENERAL CHARACTERISTICS

The radiators with tubular quartz insulation differ from those with ceramic insulation for the heating and cooling velocity. Therefore, they are best suited for all heating systems in which a rapid energy emission in the ON phase (full power provided) and a rapid cooling in the OFF phase (no or partial power provided) is requested.

The radiators with tubular quartz insulation have a low thermal inertia: their quick response time allows, in several cyclical applications, to stop or reduce the power supply when no heating is requested and to restart it very quickly (5-10 seconds) when it is requested again. This allows important energy savings, especially when huge radiation heating systems are employed in the process.

QUARTZRED radiators guarantee:

- Long operational life
- Fast heat transmission
- Resistance to corrosion
- Perfect heating uniformity
- Easy installation

TECHNICAL DATA (see Figure 15)

1. **RESISTIVE WINDING** spiral made of Nickel/Chrome 80/20 DIN 17470, material n° 2.4869
2. **INSULATION** made of tubular quartz (SiO_2) which presents a high resistance to thermal shocks and a high dielectrical rigidity
3. **LATERAL INSULATOR** made of ceramic
4. **COVER BOX** made of reflecting stainless steel
5. **POWER SUPPLY CABLES** made of Nickel, insulated using ceramic bushes resistant to high temperatures
6. **FIXATION SCREWS** 2 screws Φ M5 x 30 per box

STANDARD DIMENSIONS

QUARTZRED radiators that are available on stock have dimensions 247 x 63 mm and power as specified in Table 2. To install them, a set of panels, available in lengths ranging from 250 mm to 1500 mm, has been developed.

Table 2: QUARTZRED radiators characteristics

Code	Power at 230 V (W)	Specific Power (W/cm^2)
26IQ0632470250	250	1.8
26IQ0632470300	300	2.1
26IQ0632470400	400	2.75
26IQ0632470500	500	3.35
26IQ0632470600	600	4.1
26IQ0632470750	750	5.05

Figure 16: IQ radiators envelope dimensions

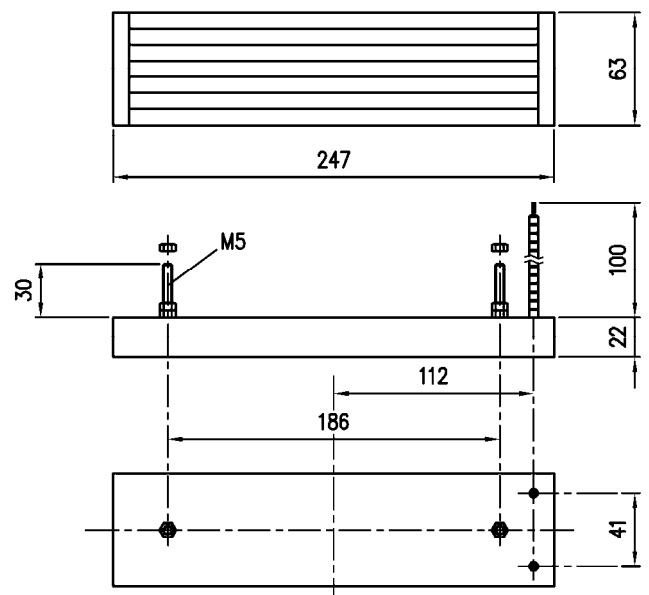

SPECIAL CONSTRUCTIONS

Upon request, QUARTZRED radiators characterised by supply voltage and power which are different from the standard can be supplied.

Mounting panels with dimensions different from the standard can also be requested.

RAD TYPE IQ MOUNTING PANELS

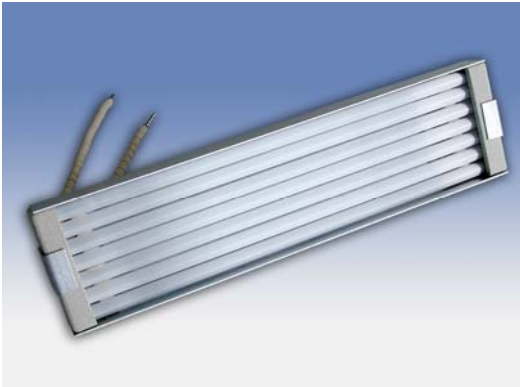

RAD IQ panels are designed to allow the installation of **QUARTZRED radiators IQ 247 x 63**.

They consist of a U-shaped structural support made of aluminised steel. If requested, a protection box, to enclose all the electrical contacts, can be provided (see solutions OPEN PANEL and CLOSED PANEL in Figure 18)

The U-shaped support is perforated to make the routing of the cables possible and to allow the fixation of the electrical terminals. The U-shaped support and, if foreseen, the protection box are assembled with the radiators as shown in Figure 17 aside.

Also for QUARTZRED radiators both "External Fixation" panels and "Internal Fixation" panels can be requested (see description provided in the area dedicated to RAD IC panels).

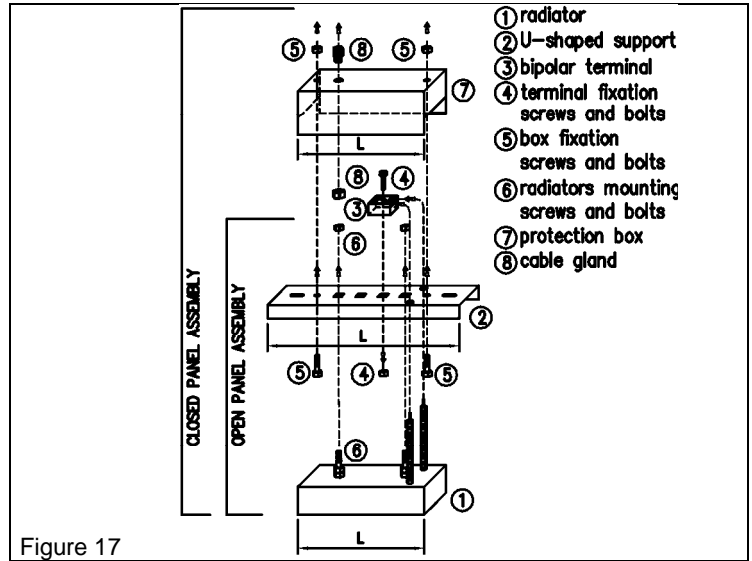
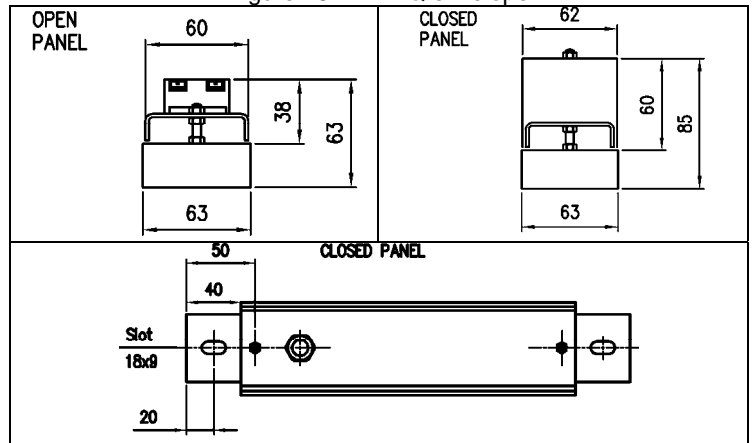
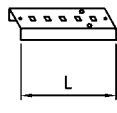
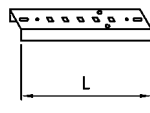
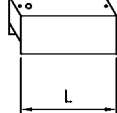
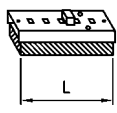
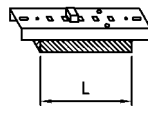
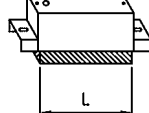

Figure 17

Figure 18: RAD IQ envelope



U-SHAPED SUPPORT With INTERNAL FIXATION	U-SHAPED SUPPORT With EXTERNAL FIXATION	PROTECTION BOX	OPEN PANEL with INTERNAL FIXATION	OPEN PANEL with EXTERNAL FIXATION	CLOSED PANEL	QUARTZRED QUANTITY
 L mm	 L mm	 L mm	 L mm	 L mm	 L mm	IQ 247 x 60
250	330	250	250	250	250	
Code 756208970	Code 756208978	Code 756208986				
500	580	500				
Code 756208971	Code 756208979	Code 756208987				
750	830	750				
Code 756208972	Code 756208980	Code 756208988				
1000	1080	1000	1000	1000	1000	
Code 756208973	Code 756208981	Code 756208989				
1250	1330	1250				
Code 756208974	Code 756208982	Code 756208990				
1500	1580	1500				
Code 756208975	Code 756208983	Code 756208991				

⑦ ⑧ BIPOLAR TERMINAL WITH SCREWS AND BOLTS (1 Terminal per radiator) CODE: M538ST021108B

④ ⑤ INSTALLATION KIT COMPOSED BY SPACERS, SCREWS AND BOLTS (1 Kit per reflecting bow) CODE : 4229TP02

Алматы (7273)495-231
Ангарск (3955)60-70-56
Архангельск (8182)63-90-72
Астрахань (8512)99-46-04
Барнаул (3852)73-04-60
Белгород (4722)40-23-64
Благовещенск (4162)22-76-07
Брянск (4832)59-03-52
Владивосток (423)249-28-31
Владикавказ (8672)28-90-48
Владимир (4922)49-43-18
Волгоград (844)278-03-48
Вологда (8172)26-41-59
Воронеж (473)204-51-73
Екатеринбург (343)384-55-89

Иваново (4932)77-34-06
Ижевск (3412)26-03-58
Иркутск (395)279-98-46
Казань (843)206-01-48
Калининград (4012)72-03-81
Калуга (4842)92-23-67
Кемерово (3842)65-04-62
Киров (8332)68-02-04
Коломна (4966)23-41-49
Кострома (4942)77-07-48
Краснодар (861)203-40-90
Красноярск (391)204-63-61
Курск (4712)77-13-04
Курган (3522)50-90-47
Липецк (4742)52-20-81

Магнитогорск (3519)55-03-13
Москва (495)268-04-70
Мурманск (8152)59-64-93
Набережные Челны (8552)20-53-41
Нижний Новгород (831)429-08-12
Новокузнецк (3843)20-46-81
Ноябрьск (3496)41-32-12
Новосибирск (383)227-86-73
Омск (3812)21-46-40
Орел (4862)44-53-42
Оренбург (3532)37-68-04
Пенза (8412)22-31-16
Петрозаводск (8142)55-98-37
Псков (8112)59-10-37

Пермь (342)205-81-47
Ростов-на-Дону (863)308-18-15
Рязань (4912)46-61-64
Самара (846)206-03-16
Саранск (8342)22-96-24
Санкт-Петербург (812)309-46-40
Саратов (845)249-38-78
Сеvastополь (8692)22-31-93
Симферополь (3652)67-13-56
Смоленск (4812)29-41-54
Сочи (862)225-72-31
Ставрополь (8652)20-65-13
Сургут (3462)77-98-35
Сыктывкар (8212)25-95-17
Тамбов (4752)50-40-97

Тверь (4822)63-31-35
Тольятти (8482)63-91-07
Томск (3822)98-41-53
Тула (4872)33-79-87
Тюмень (3452)66-21-18
Ульяновск (8422)24-23-59
Улан-Удэ (3012)59-97-51
Уфа (347)229-48-12
Хабаровск (4212)92-98-04
Чебоксары (8352)28-53-07
Челябинск (351)202-03-61
Череповец (8202)49-02-64
Чита (3022)38-34-83
Якутск (4112)23-90-97
Ярославль (4852)69-52-93

Россия +7(495)268-04-70

Казахстан +7(7172)727-132

Киргизия +996(312)96-26-47

www.masterwatt.nt-rt.ru | | mwa@nt-rt.ru